

PART F SCHEDULE TL[©]

DIAGRAMS – HOLDEN

Note: Diagrams are indicative and not to scale.

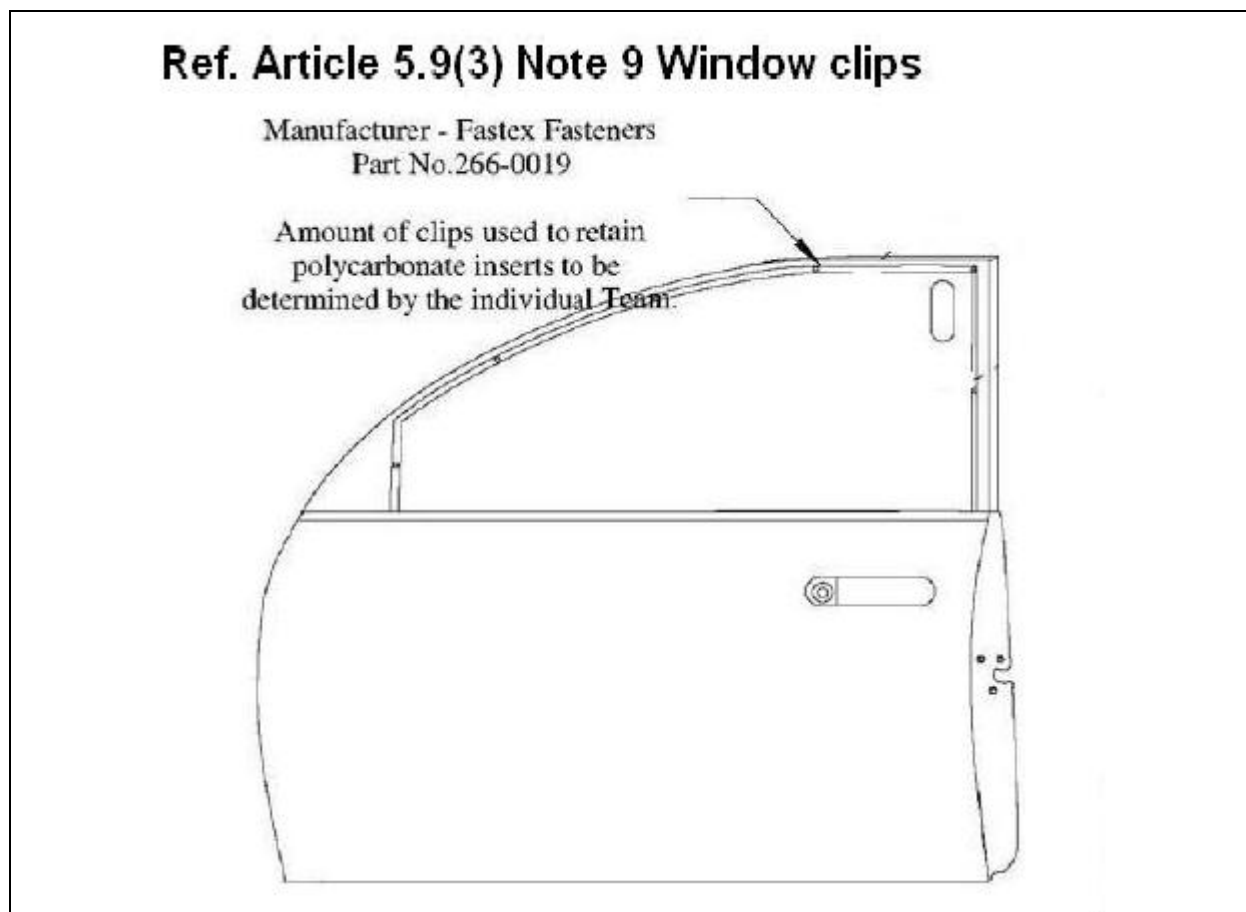
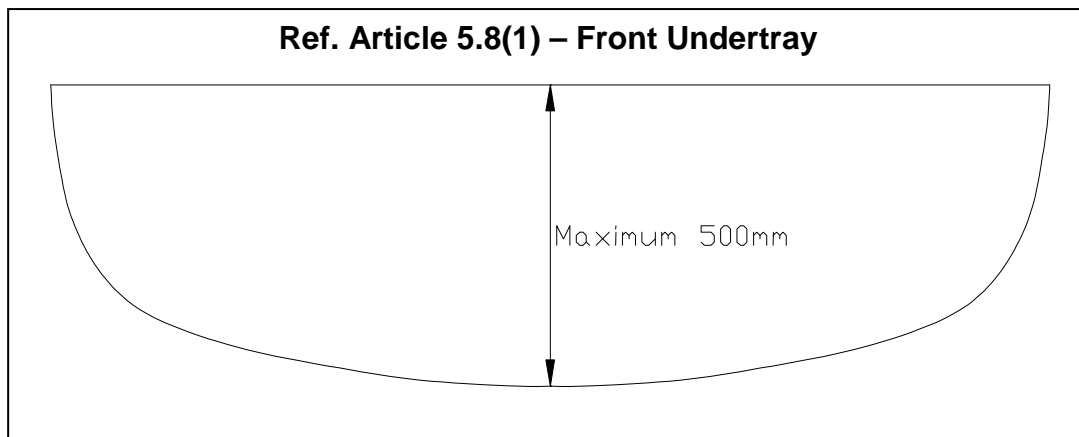

Ref. Article 7.2(4) - Mandatory Areas Requiring FIA Roll Protection Padding

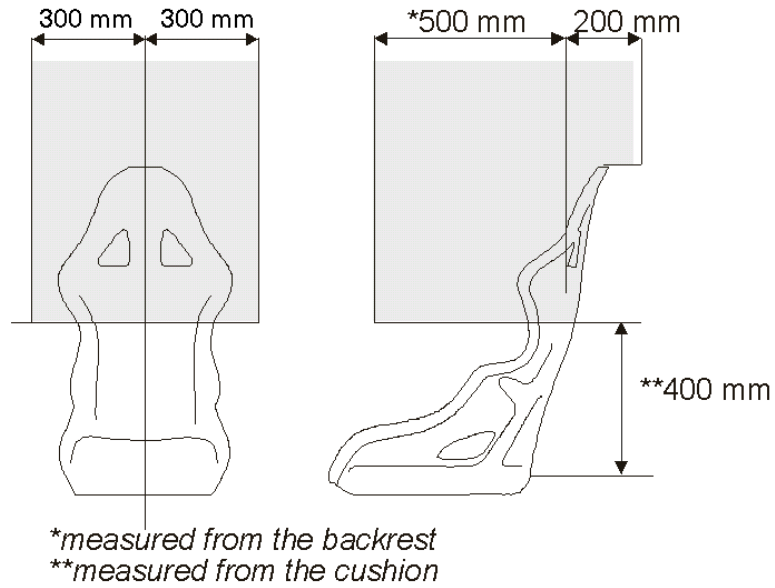

Ref. Article 7.7(1) Side Impact Structure

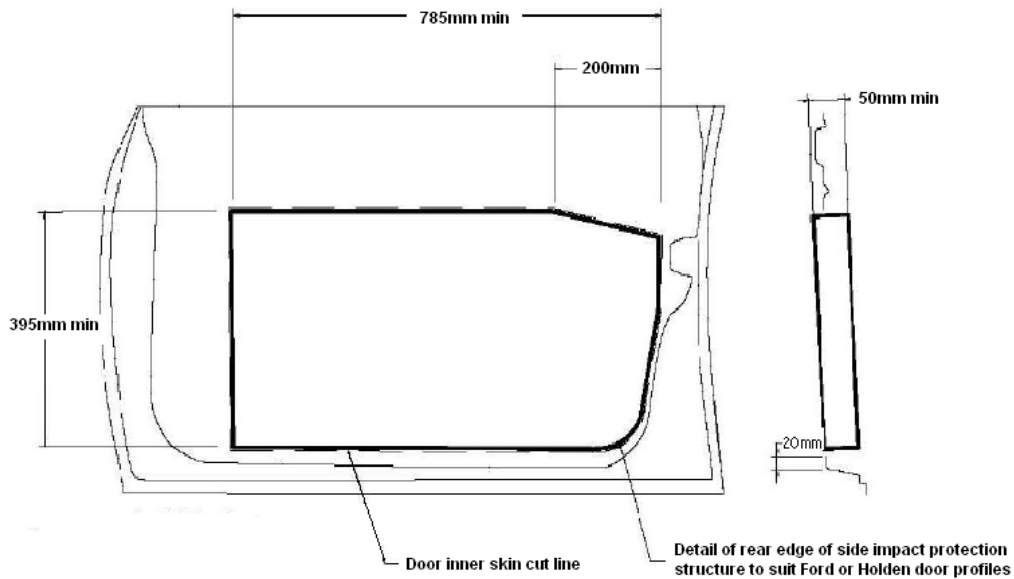

Permitted modifications to the driver's door:

The inner door skin may be removed to accommodate the side impact structure as shown on the cut line. The side impact structure must be attached to the remaining inner door skin to provide additional strength to the door. It is recommended that the side impact structure be positioned as close as possible to the door cross of the safety cage when the door is closed.

The honeycomb structure (Ayrelite 2022) requires edging prior to fitment and may be modified to accommodate the door lock and inside door handle.

Ref. Article 9.2(1) – Front Track Measurement

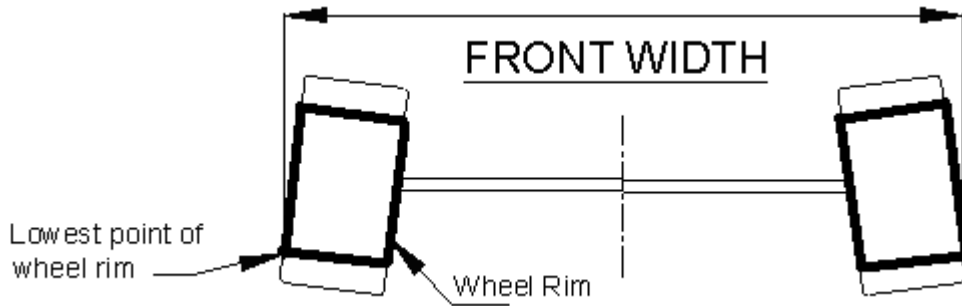

Ref. Article 9.9(1) – Rear Track Measurement

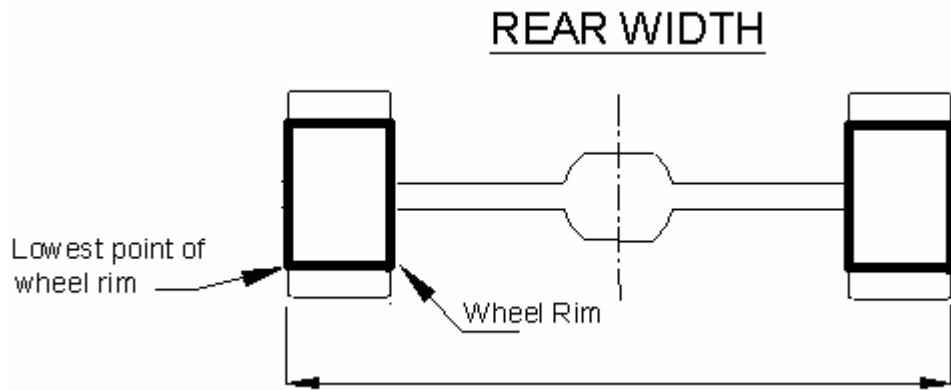

Ref. Article 9.3(1) – Inner Mount Position for Front Track Control Arm

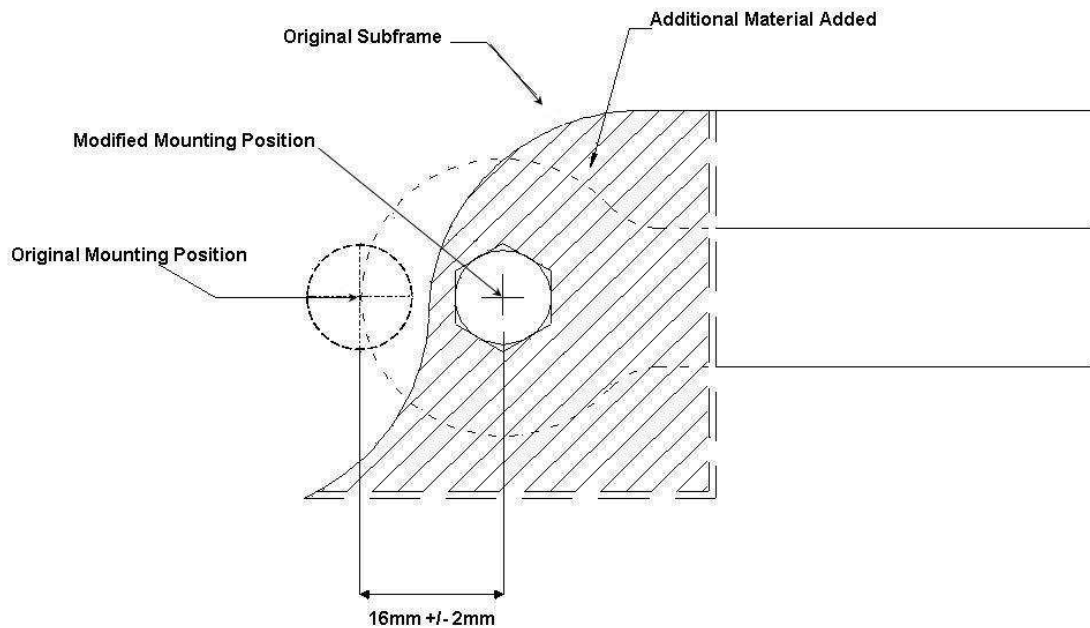

Ref. Article 9.6 (2) - Detail of Front Suspension Top Mounting

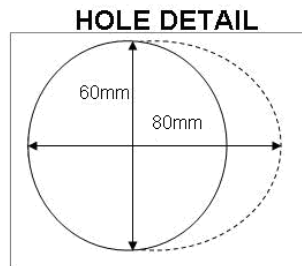
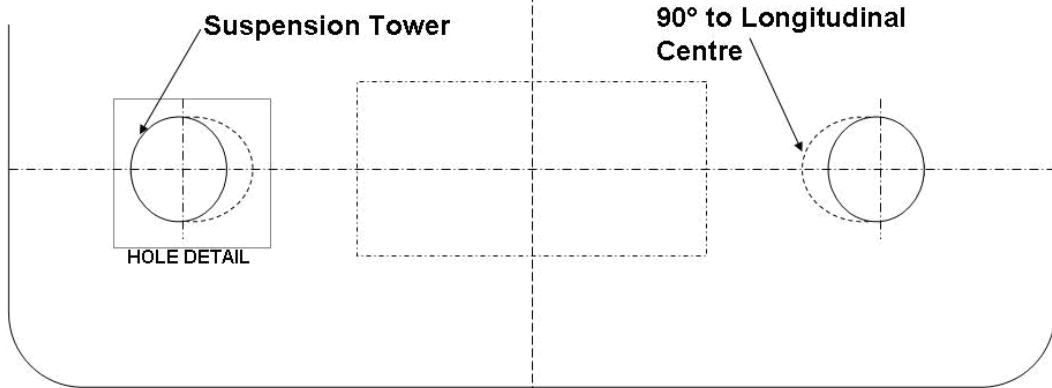

Ref. Article 11.9(1) - Clarification for Combustion Chamber Conformity.

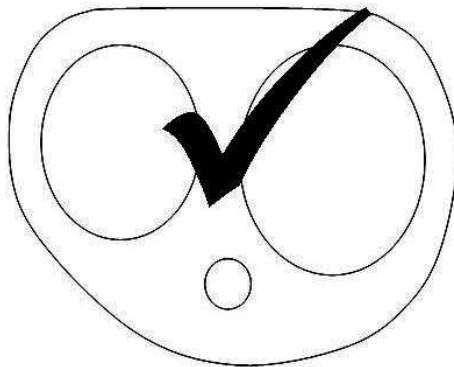

Authorized

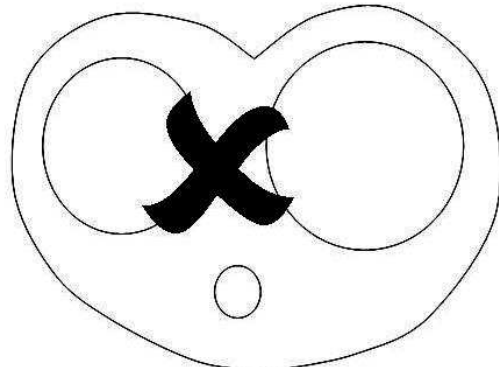

Non-authorized

Ref. Article 11.14(4) – Air Cleaner Location

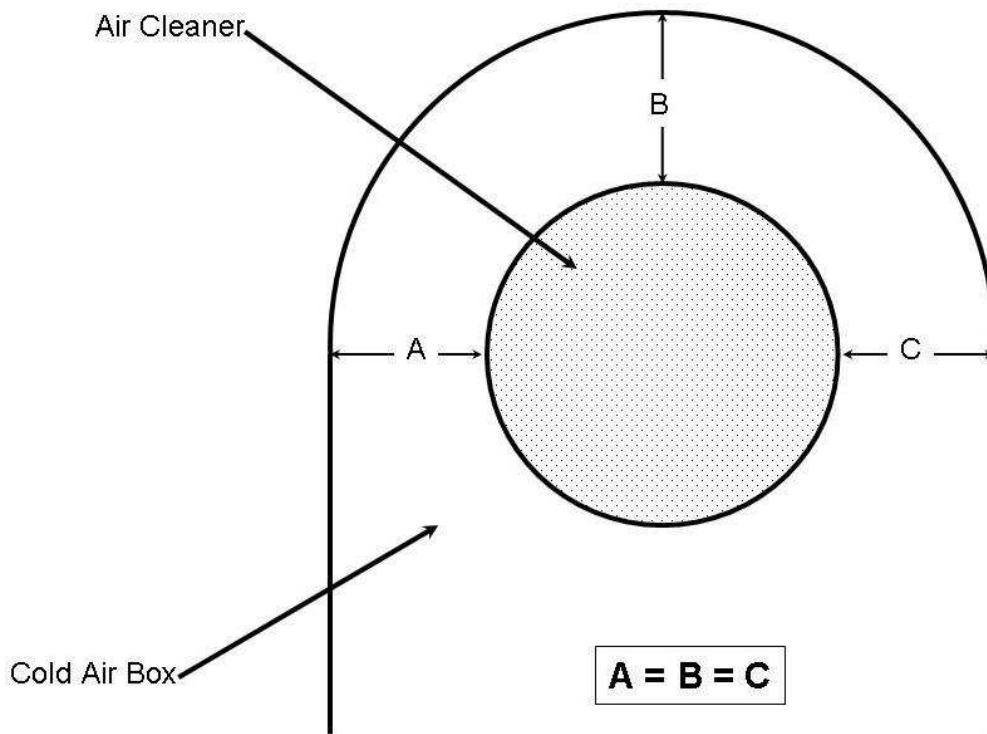

Ref. Article 15.2(1) – Defined Boot Floor Area

FRONT

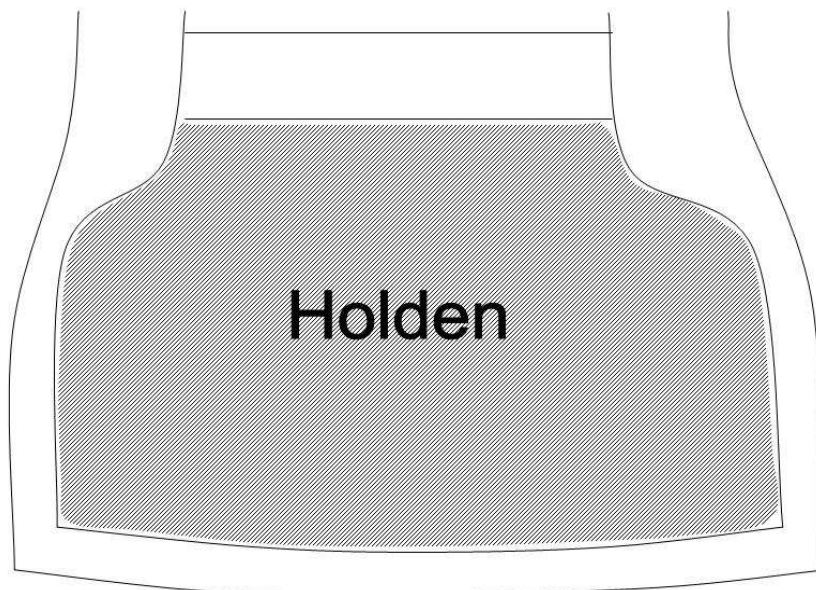

Ref. Article 16.1(1) - Circuit Breaker External Marking

